

## ORIGINAL RESEARCH ARTICLE

## Assembling and Testing of a Microcontroller Based Smart System Suitable for Controlling Brushless Fan

Surajo Aliyu<sup>1\*</sup>  and Ziya'ulhaq Sagir<sup>2</sup> <sup>1</sup>Department of Computer Software Engineering, Katsina State Institute of Technology and Management, Nigeria.<sup>2</sup>Department of Physics, Isa Kaita College of Education Dutsin-ma, Nigeria.**ABSTRACT**

This research focuses on testing and assembling of a microcontroller based smart system suitable for controlling brushless fan that will detect temperature in a room, maintain and adjusts a speed of a cooling fan. The automation system comprises of Arduino Uno board, Microcontroller, temperature sensor, DC brushless motor and other electronics components. The Atmega328P-PU Microcontroller was used in programming the system, the microcontroller coordinates the functions of the entire system and the Pulse Width Modulation (PWM) signals from the microcontroller served as regulatory tools to the fan. All the components were tested and gave out the desired result. Potentiometer was used initially before placing the LM35 temperature sensor by using hot soldering iron which corresponds with voltage values between 0-5V on Multimeter reading and 5 to 254 serial monitor reading by varying the duty cycle 0 to 100 with approximately 500Hz frequency. Six different temperature values were obtained from the circuit by varying the LM35 temperature sensor and responds to the amount of heat supplied which regulate the cooling fan on regular basis. The current temperature values displayed on LCD screen, also the aimed of the work has achieved.

**ARTICLE HISTORY**

Received August 30, 2022

Accepted September 27, 2022

Published September 30, 2022

**KEYWORDS**

Microcontroller, temperature sensor, DC brushless motor, Programming, MOSFET.

© The authors. This is an Open Access article distributed under the terms of the Creative Commons Attribution 4.0 License (<https://creativecommons.org/licenses/by-nc/4.0/>)

**INTRODUCTION**

With the advancement of technology, electronic devices are becoming more complex moving from micro to Nano technology, the devices are seriously generating heat which might lead to burning some components inside or the whole device. Apart from working in good environment, the need for the electronic devices to have cooling system cannot be over emphasized, as it would make them work more efficiently, effectively and have a long life span.

Electric fan is one of the most popular electrical appliances due to its cost effectiveness and low power consumption advantages (Bahar and Baowaly, 2017). Nowadays, the usage of fan is controlled manually by pressing on the switch button. This non-innovative feature makes it unable to turn on automatically according to temperature changes. So, an automatic temperature control system technology is applied for the switching purpose in this circuit. Due to its advantages, many researches focusing on automatic temperature control system application in different fields will gain the benefits. For examples, an automatic temperature controller for multielement array hyperthermia systems (Chengxiang, et

al., 2011), multi-loop automatic temperature control system design for fluid dynamics (Fiedler and Landy, 2014), design of automatic temperature control system on laser diode of erbium-doped fiber source (Rajarithnam, et al., 2019), the automatic temperature system with Fuzzy self-adaptive Proportional-Integral-Derivative (PID) control in semiconductor laser (Sathishkumar and Rajini, 2015).

Electric fans are designed to create a breeze and circulate air in a room. A good fan can make a room feel 10-15 degrees cooler when used properly (Jahlool, 2017). Electric fans are pretty simple in their design and function. An electric motor spins the blades, which are shaped to move air from the back of the fan out through the front of the fan. The important parts of a ceiling fan are the electric motor, paddles or blades, down rod and switches (Nurain and Dalila 2021).

Since a fan creates its cooling effect by speeding, thus, the most important part of a fan is its speed controller. Electric fan come in a different way of operating method, that is depend on the manufactures and style.

**Correspondence:** Surajo A. Department of Computer Software Engineering, Katsina State Institute of Technology and Management, Nigeria. ✉ [asurajo@gmail.com](mailto:asurajo@gmail.com) Phone: +2348032826590

**How to cite:** Surajo A. and Ziya'ulhaq S. (2022). Assembling and Testing of a Microcontroller Based Smart System Suitable for Controlling Brushless Fan. UMYU Scientifica, 1(1), 286 – 291. <https://doi.org/10.56919/usci.1122.037>

The conventional fans are operated by pull-chain control or capacitor-stepped wall control. In contemporary day nowadays, a luxurious feature offered on many modern ceiling fans that speed is controlled by the hand-held wireless remote control. These types of fan are typically having three or five of speed control (Rajarithnam, *et al.*, 2019).

Modern electronics has provided the consumer with the ability to remotely control a variety of household appliances. However, there has not yet been exploited with automatic control of ventilation devices, or more particularly to the control of fan's speed. In operation to control speed a fan, it is often necessary to physically adjust the fan in order to increase the degree of ventilation provided, or substantially change the direction of air flow. The ability to automatically change the speed of fan via changes of surroundings temperature would allow the user to feel comfort without physically to change the speed of fan.

The automatic control of this operation would further aid in the use of such a fan by those who are sick, handicapped or elderly. Moreover, this device is very suitable to be used in extensive area, hospital and children's room. This new invention will satisfy a person needs to make life easier and better. All the mundane household chores are done without having to think about those works.

Technology for automated temperature control systems for cooling fans would be used throughout the development of the smart system. Many tasks that were previously carried out by brushed DC motors are now completed by brushless motors, however the high cost and sophisticated control requirements prohibit brushless motors from totally replacing brushed motors in the lowest-cost applications (Shivshankar, *et al.*, 2020). Even so, brushless motors now predominate in a wide range of applications, especially those involving transportation, heating and ventilation, industrial engineering, motion control technology, model engineering, and radio-controlled cars (Sigh, Dhar and Roy, 2017).

The performance evaluation of a Proportional Integral Derivative (PID) controller constructed with a clear purpose to manage the temperature of a ventilation system was proposed by Apado *et al.* (2013). The models were verified through simulation using Matlab/Simulink, and the Zeigle-Vichol tuning method was used as a tuning tool to change the PID controller's parameters in order to get the system to respond in a desirable way to unit step input. The PID controller, which is implemented on a microcontroller and temperature sensor, underlies the circuit's functionality (LM35).

The PID controller control method compares the electrical signal that the temperature sensor transforms from temperature change to temperature change before activating the fan to cool the system. The microcontroller accepts input from a straightforward four-key keypad that enables specification of the set point temperature. It then uses an LCD display to show both the set point and the observed chamber temperature. Finally, a relay that turns

the fan on and off is driven by a Pulse-Width Modulation (PWM) output from the controller (Jahloul, 2017).

Ismael *et al.* (2013) suggested a novel prototype design for an electric fan with intelligent features. A microcontroller is used by the electric fan to generate an automatic operation. It uses two fans, two light emitting diodes (LEDs), and two sensors, among other uncommon double feature designs. The electric fan will automatically switch in response to changes in the outside temperature. A microcontroller is used in the circuit to control the fan in response to changes in temperature. The integrated circuit (IC) LM 35, which the system uses to gauge temperature, controls the fan in accordance with the programming's setting values. The system displays the temperature on the liquid crystal display (LCD) after receiving information about it from the PIC16F876A. Following that, the temperature is compared to the setting value. The fan will turn on if the room temperature rises above the current level.

Imam (2010) gave an example of how to construct an automatic cooling system. Any independent system or procedure that needs temperature monitoring and control can incorporate the system. An automatic cooling system that can be integrated with other systems or processes is implemented by this program. Anytime the ambient temperature reaches the defined threshold, the system detects it and activates the cooling fan and high temperature indicator LED attached to it. Programming was done using flow code, which was then downloaded or compiled to the microcontroller on the phase plus board to evaluate the system's operation.

The smart system used in this study uses a temperature sensor, microprocessor, and liquid crystal display LCD to regularly monitor and operate the cooling fan and to minimize problems as much as possible. The microcontroller would read the temperature change from the data at its input ports after being converted to a digital form by the ADC port, which would sense changes in temperature. Since a microcontroller serves as the system's brain, the setup is efficient and low-loss. The entire setup becomes user-friendly since the system uses a Liquid Crystal Display (LCD) to tell the user continuously about the state of the room temperature (Dele and Kolanda, 2013).

## MATERIALS AND METHODS

Here, a step-by-step design process for a smart cooling fan system using a microcontroller was explained. This was accomplished by combining hardware and software to carry out the intended outcome.

The subsequent actions were taken appropriately to ensure a successful project that could be executed;

1. A lookup of the ATmega328P-PU Microcontroller's availability for use with the Arduino Uno board.
2. A list of all employed components
3. Acquiring the required software and parts.

The materials used to design the system are listed in the table below:

**Table 1:** List of materials used in designing the system

S/N	Items	Quantity	Specification
1	Resistor	3	300Ω
2	Breadboard	1	Solder less
3	Microcontroller	1	Atmega328P-PU
4	Brushless DC fan	1	AFB0712HHB
5	Arduino	1	Uno board
6	MOSFET	2	IRFZ44N
7	Connection wires	20	Copper
8	Character-Base LCD	2	16*2 Character
9	Temperature sensor	2	LM35
10	12V Battery	1	
11	Vero board	1	

*Development*

This is the step-by-step process for turning a given idea into a useful physical system using fundamental scientific rules and principles.

Power supply unit, programming, ATmega328P-PU using Arduino Uno board as control unit, temperature sensor (LM35) served as the input unit, liquid crystal display (LCD) served as the display unit, MOSFET served as switching device, and finally brushless DC motor served as another output are all components of the automatic temperature control system.

The design was implemented using a modular approach, in which the different components of the bigger system were created separately. Each block completes its task before being assembled into a single unit to carry out the desired function.

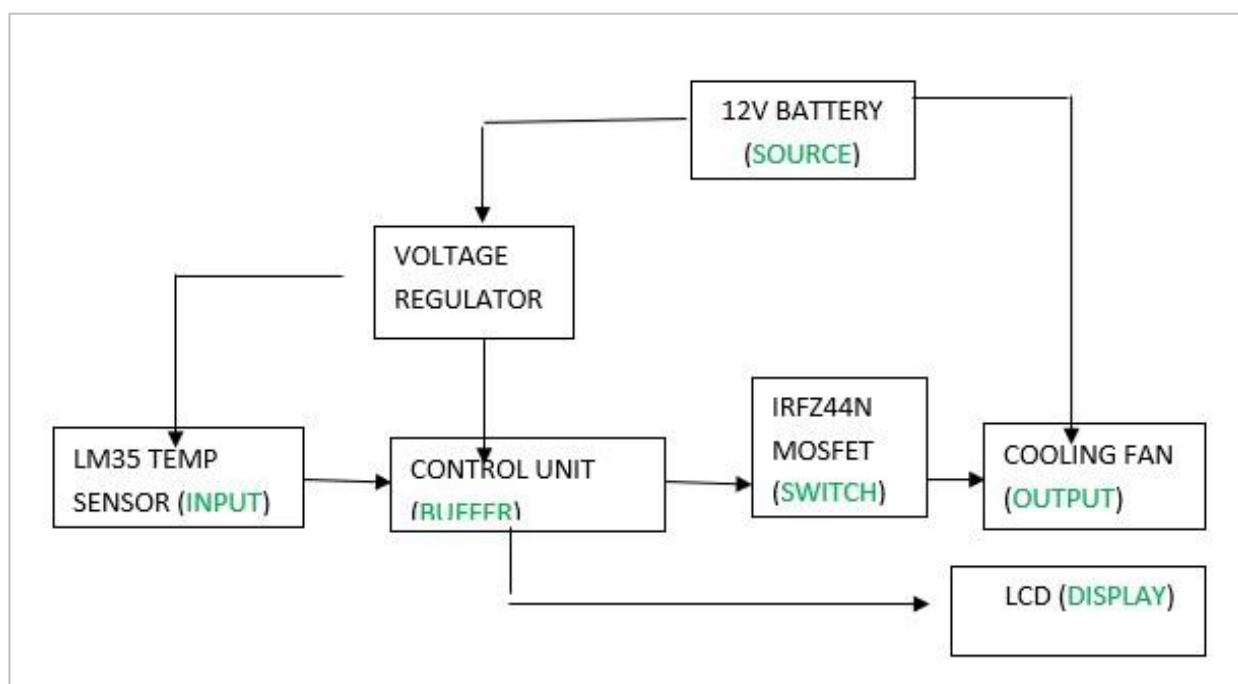

**Figure 1:** Block schematic of the system design

*Coding of Microcontroller*

The program was created in the Arduino Development Board and then downloaded to the ATmega328P-PU microcontroller. And we ensured the code entered in a proper syntax using valid command names and a valid grammar (Arduino data sheet atmel, 2009).

```

#include <LiquidCrystal.h>
LiquidCrystal lcd(12, 11, 5, 4, 3, 2);
const int analog=A1;
  
```

```

const int analogout=9;
long temperature=0;
int celcius=0;
void setup() {
  lcd.begin(16, 2);
  lcd.print("Room Temperature");
  Serial.begin(9600);
}
void loop() {
  
```

```

temperature=analogRead(analog);
celcius=temperature*0.45945;
int fandrive=map(temperature,1024,0,0,255);
analogWrite(analogout,celcius);
Serial.println(temperature);
lcd.setCursor(0, 1);
lcd.print(celcius);
lcd.setCursor(2, 1);
lcd.print("'C");
delay(500);
    
```

*Construction*

Nearly the entire gadget, including the fan, MOSFET, and Arduino Uno board, was powered by an external 12 volt battery, while the LM35 was powered by the Arduino Uno board's 5 volt input. With the exception of the MOSFET source terminal, which was connected to ground via a variable resistor, all the components were connected to common ground (potentiometer). (Due to the fact that the potentiometer is attached as a voltage divider across the source voltage and the MOSFET is controlled by voltage).

The gate of the MOSFET was linked to pin 9 of the Arduino, while the drain terminal was directly connected to the 12 Volt supply. The green terminal of the fan was connected to the source of the MOSFET by omitting the potentiometer, and the positive terminal was directly connected to the battery's 12-volt supply. The fan's green terminal acted as its controller, which used the MOSFET to pass PWM signals from the Arduino to the fan. The MOSFET gate is connected to pin 9 of the Arduino via PWM signals with values ranging from 0 to 255. The analog pin Ao of the Arduino, which acted as the input pin, was directly linked to the output terminal of the LM35 temperature sensor.

The Arduino then transformed the temperature readings to digital values between 0 and 1023 values so they could be sent as PWM signals. The temperature values were first converted to voltage values between 0V and 5V at a specific input pin. As shown in figure 2 below, the full system diagram, the LCD was used as the output device to display current temperature data in °C.

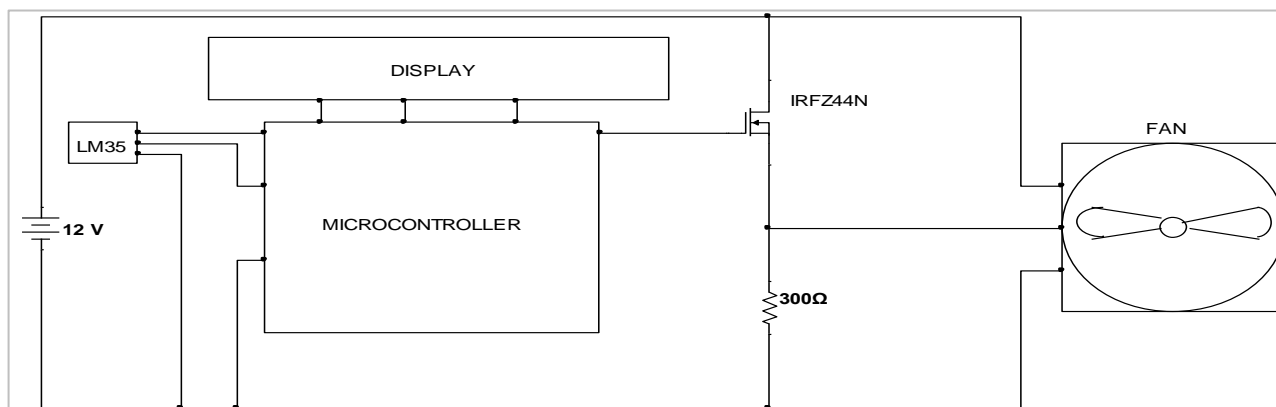

Fig.2: Circuit diagram

**RESULTS AND DISCUSSION**

*Results*

As shown in the Fig. 2 above, an automatic temperature control system employing an Arduino Uno was created and tested. The gadget operates as intended, and some values were acquired by adjusting the voltage level of the LM35 temperature sensor in relation to the corresponding serial port values.

**Table 2:** Result of the circuit with potentiometer

S/N	Serial port reading(Baut)	Multimeter reading (V)	Fan speed
1	Less than 190	Below 3.5157	Low speed
2	190-254	3.5157 and above	High speed

Table 2 shows that the fan spins with low speed at voltage level below 3.5157V value with the corresponding value less than 190 from the serial port of the test circuit.

**Table 3:** Result of the Circuit with LM35 temperature sensor

% of the Duty cycle	Multimeter reading (V)	Serial port reading (Baut)
0	0.09	5
10	0.83	45
50	1.47	75
75	1.98	107
90	3.59	194
100	4.70	254

The duty cycle is shown in Table 3 as a square wave that varies to change the amount of power delivered to the load. When the duty cycle is reduced, power across the

load drops while it increases when the duty cycle is increased. It was discovered that the exact room temperature, which corresponds to serial port 190, is 29 °C.

#### Discussion

The output pin produces an analog voltage that is linearly proportional to Celsius (centigrade) temperature at a rate of 10mV per degree. Following the receipt of each 1 C, the V output was added in 10 mV increments between 0 and 5 V.

Between 0 and 1023, analogRead returns a value that is proportional to the voltage applied to the pin; the highest value between 0 and 1023 will be 5V from the circuit's output result. On the test circuit, the input signal was adjusted using a potentiometer before the LM35 temperature sensor was connected. Table 4.1 displays the two values that were obtained, showing how the fan spins at low speed when the voltage is below 3.5157V and the corresponding serial port value is less than 190 and how the fan spins at high speed when the voltage is above 3.5157V and the corresponding serial port value is greater than or equal to 190. In order to replace the potentiometer as the input device, an LM35 temperature sensor was connected. Six different values were noted, where each voltage level value matched the value of the serial port at each specific duty cycle.

When enough voltage is provided to the gate, the switch is switched ON, creating the channel that enables current to flow between the drain and source in the IFRZ44N MOSFET, which operates similarly to a resistor and is controlled by the gate voltage connected to both the source and drain voltages. The PWM signals, which vary the duty cycle with 454Hz frequency observed from oscilloscope and 489Hz frequency from multimeter reading, control the speed by operating the fan with a sequence of ON-OFF pulses. The speed of the fan was controlled by altering or modifying the time of these pulses; for example, the larger the pulse, the faster the fan will rotate, and the shorter the pulse, the slower the fan will rotate.

Main issues those were present when testing the device. We observed that the fan would stop spinning for a while until the temperature dropped and corresponded to the specified value of 5V, at which point it started spinning again. This happened when the voltage supply value surpassed the predefined value (5V), which resulted in over flooding. But after careful consideration and collaboration, we fixed the issue by switching the setup's limited values from byte to integer. The over flood problem was resolved by using an analogRead, which produces a number between 0 and 1023 that is proportionate to the amount of voltage being applied to the pin between 0V and 5V. The other problem was that, the time interval for the fan to switch to the next level was noticeable. This was overcome with the introduction of delay 500 milliseconds between the switching responses of the voltage level to the fan.

## CONCLUSION

All of the device's evaluated components produced the anticipated outcome, demonstrating that it was conceived, tested, and confirmed to perform efficiently. LM35 temperature sensor was first utilized with a potentiometer, and two different values were obtained by altering the potentiometer. The potentiometer was then used in place of the LM35 temperature sensor. As a result, six different values were obtained from the circuit by varying the temperature sensor with a hot soldering iron. These values correspond with voltage values between 0 and 5 volts on multimeter readings and 5 and 254 serial monitor readings by varying the duty cycle 0 to 100 with roughly 500 Hz frequency. In response to the amount of heat applied, the cooling fan automatically adjusts itself on a regular basis. The LCD panel then shows the temperature readings as of this moment.

## REFERENCES

- Apado K.A, Ezeagwu C.O, Ejiofor A. and Nwokele A.O. (2013). Design, modeling and simulation of a microcontroller based temperature control in ventilation system. Internal Journal Advanced Research in Electrical Electronics and Instrumentation, Vol. 2
- Bahar A.N., Baowaly M.K., (2017). An Intelligent Approach of Regulating Electric-Fan Adapting to Temperature and Relative Humidity. International Journal Intelligent Systems and Applications, 4 (7), pp. 61-69, 2017. [\[Crossref\]](#)
- Chengxiang L., Y. Zhenhua, W. Xu, L. Feng, (2011). Design of Automatic Temperature Control System on Laser Diode of Erbium-Doped Fiber Source. International Conference on Intelligent Computation Technology and Automation, pp. 404-407. [\[Crossref\]](#)
- Dele A.W.S and Kolanda K.K. (2013). Microcontroller Base Green House Control. International Journal of Engineering and Science (IJTS), Vol.2 pp. 129-135.
- Fiedler G.J., J. Landy (2014). Multi-loop Automatic Temperature Control System Design for Fluid Dynamics Facility Having Several Long Transport Delays. IEEE IRE Transactions on Automatic Control, 4 (3), pp. 81-96. [\[Crossref\]](#)
- Imam A.S (2010). Mechatronics for Beginners 21 project for PIC Microcontrollers: Automatic cooling system, pp: 321-348.
- Ismael Z.R, Ho K.Y, Ismail N, Mohamad N and Nur H.R.H (2013). Design an Automatic Temperature Control System for Smart Electric

- Fan Using PIC. International Journal of science and Research (IJSR), Vol.2 (A).
- Jahlool J. S., (2017). Design and Simulation of Automatic Temperature Control and Alert System Based PIC16F887. Vol. 6, no. 2, pp. 95-104. [[Crossref](#)]
- Jonathan O. O., Garba M. R. and John D. G (2014). Building of Smart system using Mechatronic Engineering. A case study of 'Smart Door' system. Journal of Computer Engineering, 16(5): 78-84. [[Crossref](#)]
- Nurain Hidayah Md. Nasir, Dalila Mismar (2021). IOT Smart Room Temperature based Microcontroller. Progress in Engineering Application and Technology. Vol. 2 ppg 1169-1181. ISSN: 2773-5303. [[Crossref](#)]
- Rajarithnam D. R. P, Kumaravel S. T., Surya A., M. Vinoth, V. Subash (2019). Automatic Temperature Based Fan controller using thermistor. International journal of research in Engineering, science and management. Volume-2, ISSN: 2581-5792
- Sathishkumar M., Rajini S., (2015). Smart Surveillance System Using PIR Sensor Network and GSM. International Journal of Advanced Research in Computer Engineering & Technology (IJARCET) Volume 4.
- Shivshankar Adsule, Shivani Mohite, Rahul Putil, Prof. Namrata R. Dhawas (2020). Automatic Temperature Based Fan speed controller using Arduino. International journal of Advanced Research in science and technology (IJARST) Vol. 2, ISSN: 2581-9429
- Singh K., M. Dhar, P. Roy,( 2017). Automatic fan speed control system using Arduino, ISSN: 2456-4184 International Journal of Novel Research and Development (IJNRD).